



**JIMCO**<sup>®</sup>

UV-C & OZONE  
Technology

# HS PURIFIER

HYDROGEN SULFIDE REDUCTION

# ENVIRONMENTALLY FRIENDLY TECHNOLOGY

---

For more than 25 years the Danish company JIMCO A/S has developed and manufactured some of the world's most unique environmentally friendly purification technologies. JIMCO's technology can be used to purify both air and water without the use of chemicals.

JIMCO has won EU's environmental award for cleaner technologies by utilizing the use of photolytic oxidation to purify air and water:

JIMCO has a goal to reduce the global use of chemicals by informing stakeholders about the environmentally friendly solutions offered by JIMCO.

The HS Purifier uses photolytic oxidation to purify hydrogen sulfide (H<sub>2</sub>S) in the air. When the amount of H<sub>2</sub>S is reduced significant in a pump well you will avoid neighbors complaining about odor and you will protect your electrical installations against the corrosive gas.

# FACTS OF HYDROGEN SULFIDE

---

Hydrogen sulfide is an inorganic chemical compound with the formula H<sub>2</sub>S. Hydrogen Sulfide is very poisonous, corrosive, and flammable and a mixture of H<sub>2</sub>S and air can be explosive.

Hydrogen sulfide is normally produced by the breakdown of organic matter and human/animal wastes. The corrosive poisonous gas occurs mainly in poorly ventilated areas such as basements, manholes, sewer lines, underground telephone/electrical vaults, cargo of fishing boats and in sewage.

- 0.00047 ppm is the odor threshold, the point at which 50% of a human panel can detect the presence of an odor without being able to identify it.
- 10–20 ppm is the borderline concentration for eye irritation.
- 50–100 ppm leads to eye damage.
- 100–150 ppm the olfactory nerve is paralyzed after a few inhalations, and the sense of smell disappears, often together with awareness of danger.
- 320–530 ppm leads to pulmonary edema with the possibility of death.
- 530–1000 ppm causes strong stimulation of the central nervous system and rapid breathing, leading to loss of breathing.
- 800 ppm is the lethal concentration for 50% of humans with 5 minutes exposure.
- Concentrations over 1000 ppm cause immediate collapse with loss of breathing, even after inhalation of a single breath.



**HS**PURIFIER

## ADVANTAGES

# HS PURIFIER

- ✓ Ozonation is 100% effective in converting H<sub>2</sub>S to sulfates
- ✓ Reduces hydrogen sulfide effectively
- ✓ Sterilizes the air
- ✓ Odor reduction
- ✓ No complaining neighbours
- ✓ Protecting electrical installations
- ✓ Environmentally friendly purification
- ✓ Disinfects - E-coli bacteria, Zars, Etc.
- ✓ Easy to install
- ✓ Low initial cost
- ✓ Low operation and maintenance costs



## INSTALLATION

The HS Purifier is connected to a 230V power supply and is mounted vertical in an Ø110 PVC tube with the ventilator on top. The Ø110 tube ends in the pump well and the ozone will travel through the tube into the pump pit.

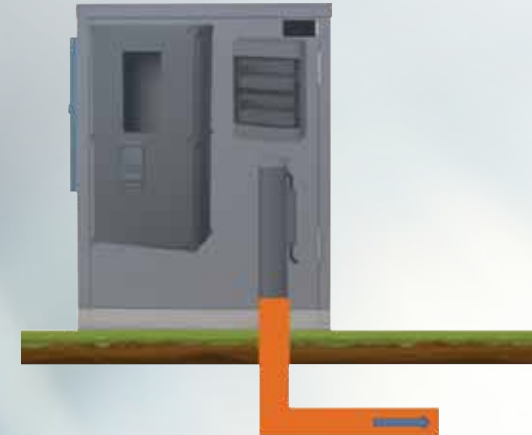

## PURIFICATION PROCESS

Oxygen in the atmospheric air is converted into ozone by using JIMCO's special HS lamp. The ozone is blown to into the pump pit by a ventilator mounted on the HS Purifier. The ozone will react with hydrogen sulfide and the following chemical reaction occurs in pump well:



This means that the hydrogen sulfide is oxidized into a sulfur compound and is therefore no longer dangerous or malodorous.



**NO  
CHEMICALS**

**Environmentally  
Friendly  
Purification**

"At Svendborg wastewater we carried out a test with JIMCO's HS Purifier and showed that it effectively reduces H<sub>2</sub>S."

*Technician Thomas Egel  
Svendborg Wasterwater*

"We use JIMCO's HS Purifier in several of our pump wells to reduce odor to the surroundings and to neutralize hydrogen sulfide. We have been working with JIMCO for more than 10 years."

*Operations Manager Bjarni Hansen  
Langelands Forsyning*

# OVERVIEW OF INSTALLATION IN WASTE WATER WELL

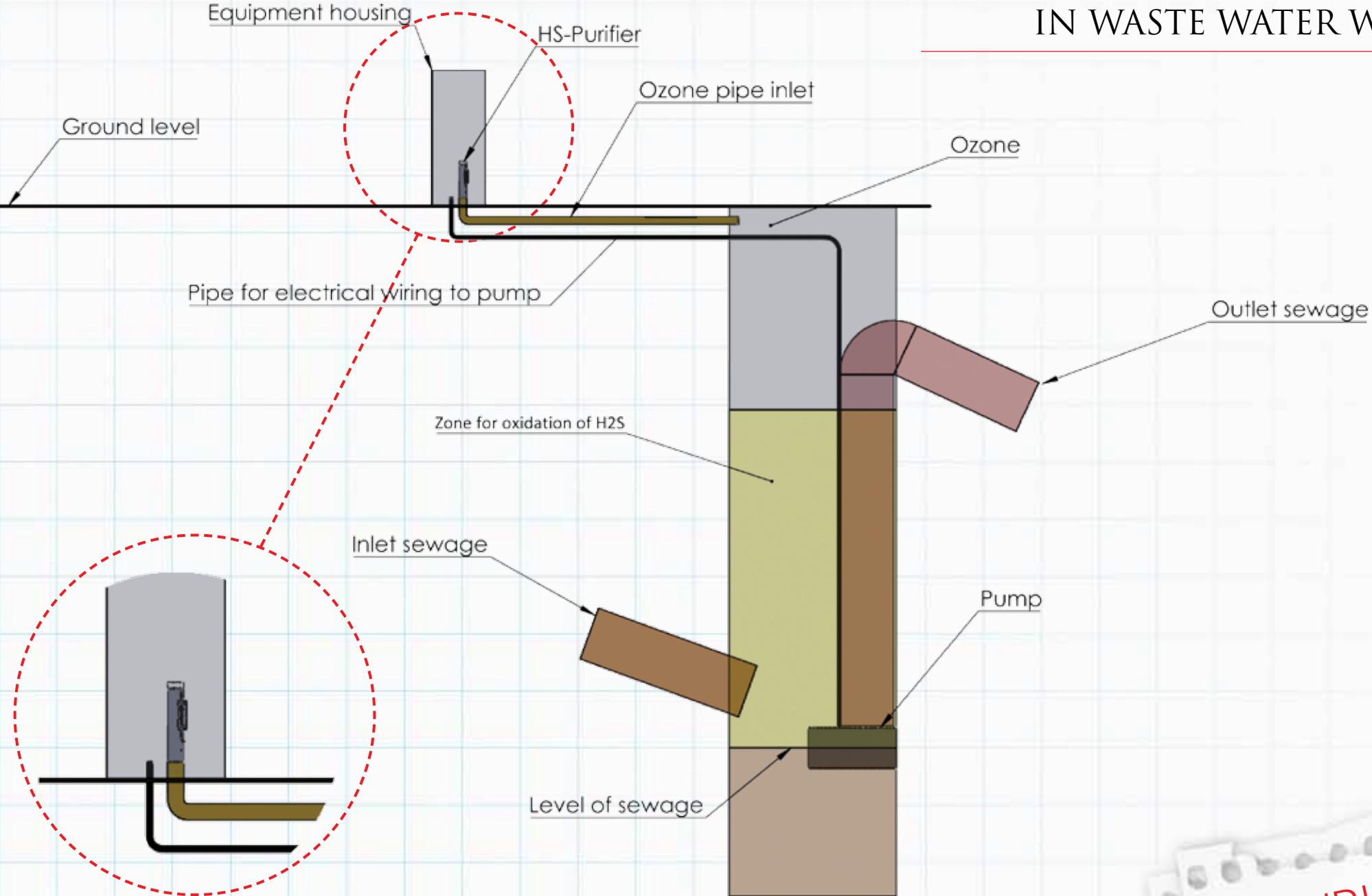

# DATASHEET

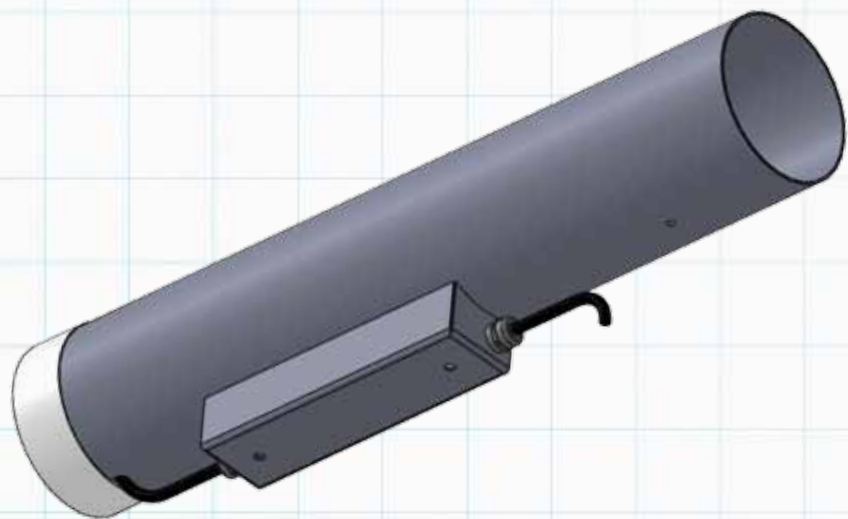
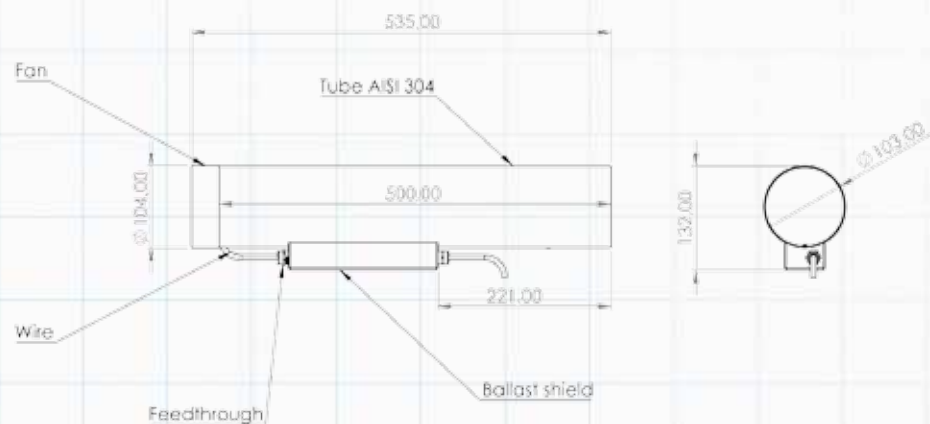

## HSPURIFIER

HS UV-C lamp: 1x16 W  
Operating hours (lamp): 8000  
Voltage: 230 V  
Power consumption: 30 W

Recommended room area: 125 m<sup>3</sup>  
Finish: Stainless steel AISI 304  
Dimensions: H: 535 mm Ø: 104 mm  
Weight: 2,62 kg



**JIMCO**<sup>®</sup>

**UV-C & OZONE  
Technology**

For further information  
please contact:

Michael Kløcker  
*Business Unit Manager*

E-mail: [mk@jimco.dk](mailto:mk@jimco.dk)

Mobil: +45 21 49 33 48

JIMCO A/S

Mjølbyvej 7 · DK-5900 Rudkøbing · Denmark

Tlf: +45 62 51 54 56 · E-mail: [jimco@jimco.dk](mailto:jimco@jimco.dk)

**JIMCO.DK**

